

Hybrid Tantalum Capacitor - HTHC3 Series

◆ Features

- Tantalum casing, hermetically sealed, cylindrical, axial leads, polarized, ultra-large capacitance;
- Small volume, large energy storage, excellent and stable electrical performance, high reliability, long lifespan; internal structure is multi-core parallel; capacitance is larger than HTHC2 series
- Provides energy storage and power interruption delay functions in DC or pulsed circuits of electronic equipment in fields such as aerospace, aviation, weaponry, electronics, shipping, and communications;



◆ Specifications:

1. Operating Temperature Range: $-55^{\circ}\text{C} \sim +125^{\circ}\text{C}$. For the Derated Design please see guide line on page 3~5
2. Capacitance Tolerance: Q: $-10\% \sim +30\%$, K: $\pm 10\%$, M: $\pm 20\%$
3. Dimensions, Maximum Weight: see Table 1
4. Structure and dimensions: see Figure 2

◆ Table 1 Dimensions and Installation instruction

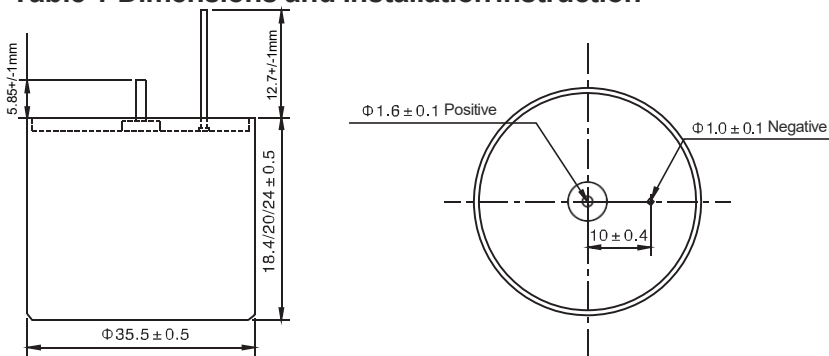

The structure and dimensions
HTHC3 $\Phi 35.5 \times 18.4/20/24$

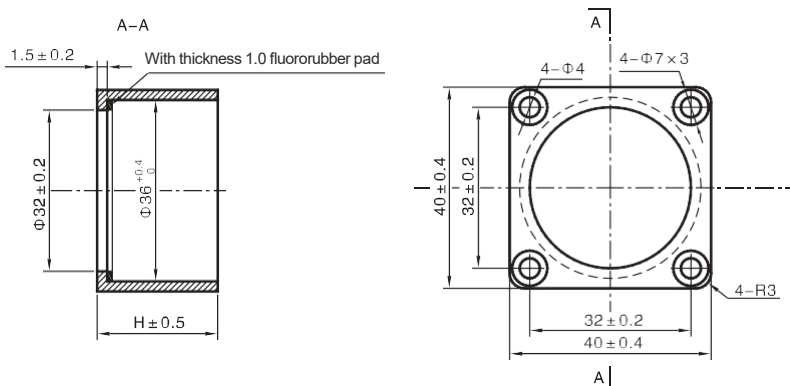

Dimensions mm	Height of fixing frame H +/-0.5mm
$\Phi 35.5 \times 18.4$	18.5
$\Phi 35.5 \times 20$	20
$\Phi 35.5 \times 24$	24

Installation and fixing frame
HTHC3 $\Phi 35.5 \times 18.4/20/24$